



**Model: SR-U270-3S**

Description: ..... SP3T, Absorptive, PIN-Switch  
Operating Frequency:..... 0.5 – 18 GHz  
Insertion Loss:..... 2.8dB Max  
Isolation (Arm-to-Arm):

0.5 – 10 GHz	10 –18 GHz
65 dB Min	55 dB Min

VSWR (RF Path “ON” or “OFF”): ..... 1.8:1 Max  
Rise/Fall time (10% to 90% RF, 90% to 10% RF): ... 20 ns Max  
On/Off time (50% TTL to 90% RF, 50%TTL to 10% RF): ..... 60 ns Max  
Operating Power: ..... CW&AVG ..... +24dBm Max  
..... Peak:..... 5W @ 1µS PW Max  
Control Input Characteristics: ..... Std. TTL / Unit-Load / Floating-High  
Control Logic: ..... 3-Controls, Logic “0” = RF Path “ON”  
Power Supplies: ..... +5(±0.25)V @ 100mA Max  
..... -12(±0.5)V @ 60mA Max  
Connectors (RF):..... SMA (f), Removable  
Connectors (Supplies/Controls) ..... Solder Pins  
Impedance: ..... 50 Ω Nominal  
Quality: ..... Best-Commercial-Grade

**Environmental Ratings:**

Temperature: ..... {Operating: -55°C to +95°C} & {Storage: -60°C to +110°C}  
Humidity:..... MIL-STD-202F, Method 103B, Cond. B (96 hours at 95% R.H.)  
Shock:..... MIL-STD-202F, Method 213B, Cond. B (75G, 6mSec)  
Vibration:..... MIL-STD-202F, Method 204D, Cond. B (.06” double amplitude, or 15G)  
Altitude:..... MIL-STD-202F, Method 105C, Cond. B (50,000 Feet)  
Temp. Shock:..... MIL-STD-202F, Method 107D, Cond. A (5 cycles)

**Available Options:**

(Units with listed options here may be subject to some specification tradeoffs from the standard, consult factory)

■ **Supply Voltages**

- A1 [ +5(±0.25)V / -5(±0.25)V ] \*
- A2 [ +5(±0.25)V / -15(±0.5)V ]
- A3 [ +12(±0.5)V / -12(±0.5)V ]
- A4 [ +15(±0.5)V / -15(±0.5)V ]

■ **Control Function**

- F1 [ Inverse Logic, (“1” = Path “ON”) ]
- F2 [ 2-Bit Binary Control ] ; see below for “Outline Drawing” and “Function Table”

■ **RF Connectors**

- B1 [ J1 – J3 Ports with SMA(M) ]
- B2 [ All SMA (M) ]
- B3 [ COM Port with SMA(M) ]

■ **Video Suppression Filter**

- G1 [ VF @ COM Port <> 0.25 dB additional Loss ]
- G2 [ VF @ J1 – J3 Ports <> 0.25 dB additional Loss ]
- G3 [ VF @ All Ports <> 0.5 dB additional Loss ]

\* Recommended for Low Power Consumption <> Additional 50ns Switching Delay (On/Off Time)



**Model: SR-U270-3S**

**Outline**

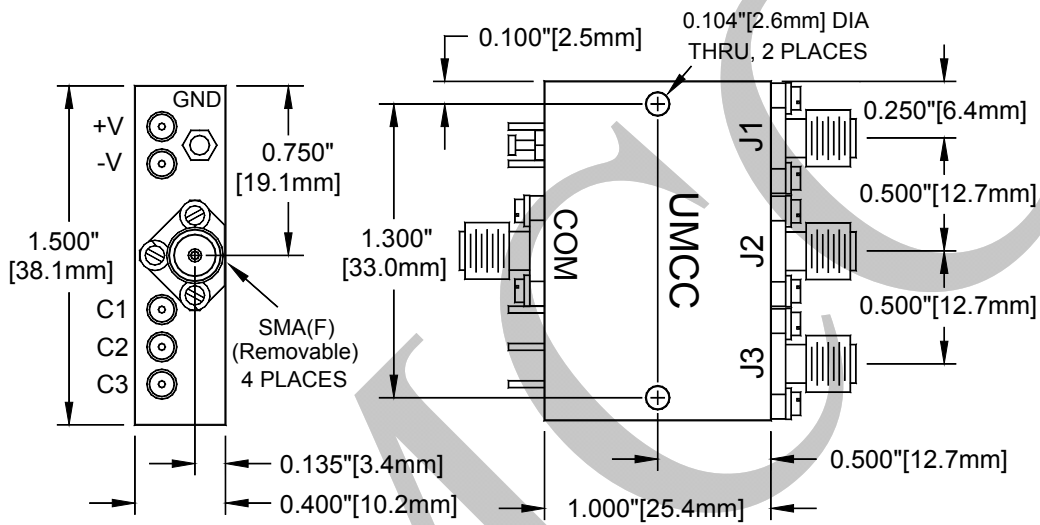

Weight	Tolerances
1.0 oz [28.3g]	±0.015" [±0.38mm]



Model: SR-U270-3S

**Outline Drawing (SP3T with Option "F2")**

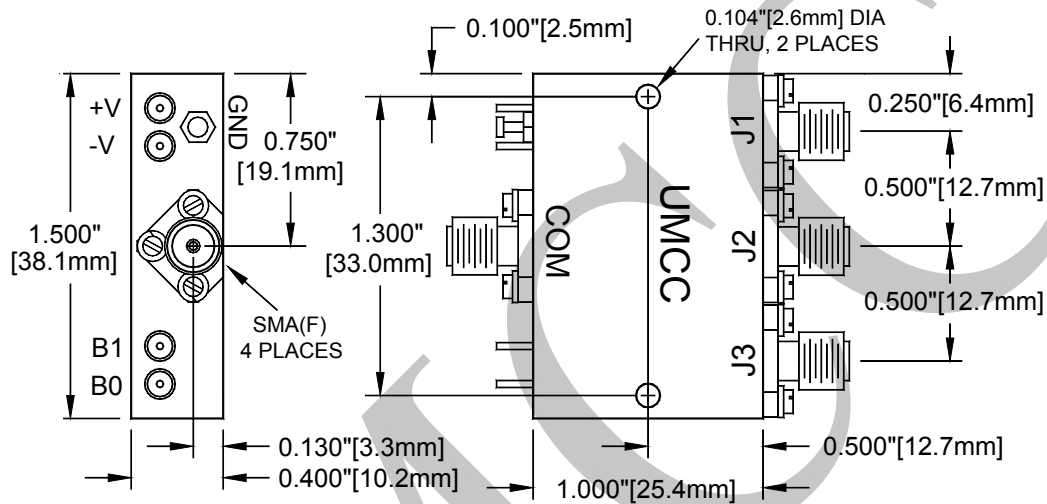

Weight	Tolerances
1.0 oz [28.3g]	±0.015" [±0.38mm]

**Function Table for Option "F2" (2-Bit Binary Control)**

INPUTS		RF PATH		
B1	B0	J1	J2	J3
0	0	ON	OFF	OFF
0	1	OFF	ON	OFF
1	0	OFF	OFF	ON
1	1	OFF	OFF	OFF