



Model: SR-DA1W-3S

Description:.....	SP3T, Absorptive, PIN-Switch
Operating Frequency:.....	0.2 – 4 GHz
Insertion Loss:	1.8 dB Max
Isolation:	75 dB Min
VSWR (RF Path “ON” or “OFF”):	1.5:1 Max
Rise/Fall time (10% to 90% RF, 90% to 10% RF): ...	250 ns Max
On/Off time (50% TTL to 90% RF, 50%TTL to 10% RF):.....	300 ns Max
Operating Power:.....	CW & AVG..... +27dBm Max *
.....	*
.....	(+24dBm Max into “JX” Port @ Off-State)
.....	Peak:
.....	5W @ 1µS PW & 10% Duty-Cycle Max
Control Input Characteristics:	Std. TTL / Unit-Load / Floating-High
Control Logic:.....	3-Controls, Logic “0” = RF Path “ON”
Power Supplies:.....	+5(±0.25)V @ 110mA Max
.....	-12(±0.5)V @ 60mA Max
Connectors (RF):.....	SMA (f), Removable
Connectors (Supplies/Controls)	Solder Pins
Impedance:	50 Ohms Nominal
Quality:.....	Best-Commercial-Grade

Environmental Ratings:

Temperature:.....	{Operating: -55°C to +95°C} & {Storage: -60°C to +110°C}
Humidity:	MIL-STD-202F, Method 103B, Cond. B (96 hours at 95% R.H.)
Shock:	MIL-STD-202F, Method 213B, Cond. B (75G, 6mSec)
Vibration:	MIL-STD-202F, Method 204D, Cond. B (.06” double amplitude, or 15G)
Altitude:	MIL-STD-202F, Method 105C, Cond. B (50,000 Feet)
Temp. Shock:	MIL-STD-202F, Method 107D, Cond. A (5 cycles)

Available Options:

(Units with listed options here may be subject to some specification tradeoffs from the standard, consult factory)

■ **Supply Voltages**

- A1 [+5(±0.25)V / -5(±0.25)V] *
- A2 [+5(±0.25)V / -15(±0.5)V]
- A3 [+12(±0.5)V / -12(±0.5)V]
- A4 [+15(±0.5)V / -15(±0.5)V]

■ **RF Connectors**

- B1 [J1 – J3 Ports with SMA(M)]
- B2 [All SMA (M)]
- B3 [COM Port with SMA(M)]

■ **Control Function**

- F1 [Inverse Logic, (“1” = Path “ON”)]
- F2 [2-Bit Binary Control] ; see below for “Outline Drawing” and “Function Table”

* Recommended for Low Power Consumption <> Additional Switching Delay (ON/OFF time)



Model: SR-DA1W-3S

Outline

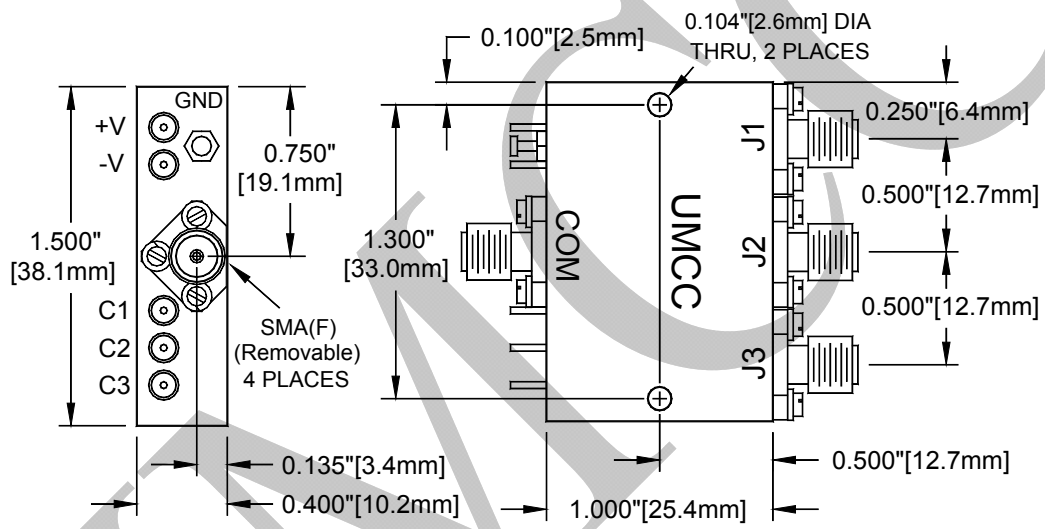

Weight	Tolerances
1.0 oz [28.3g]	±0.015" [±0.38mm]



Model: SR-DA1W-3S

Outline Drawing (SP3T with Option "F2")

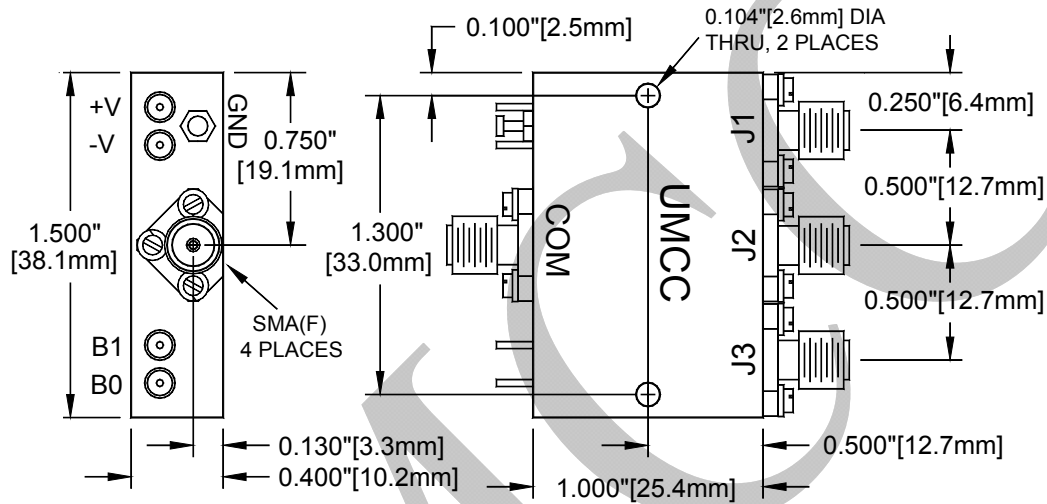

Weight	Tolerances
1.0 oz [28.3g]	±0.015" [±0.38mm]

Function Table for Option "F2" (2-Bit Binary Control)

INPUTS		RF PATH		
B1	B0	J1	J2	J3
0	0	ON	OFF	OFF
0	1	OFF	ON	OFF
1	0	OFF	OFF	ON
1	1	OFF	OFF	OFF