



Model: DC-S000-10S

Description: Directional Coupler
 Operating Frequency: 2 - 18 GHz
 Coupling (reference to input): 10 ± 1dB Nominal
 Coupling Flatness: ± 0.85 dB Max
 Insertion Loss (including coupled power): 1.4 dB Max
 Directivity:

2 - 12 GHz	12 - 18 GHz
14 dB Min	12 dB Min

VSWR: Line 1.45:1 Max
 Couple 1.55:1 Max
 Power Handling: Incident @ Input 40W Cw/Avg Max
 Incident @ Output 10W Cw/Avg Max
 Connectors: SMA (f)
 Impedance: 50 Ω Nominal
 Quality: Best-Commercial-Grade

Environmental Ratings:

Temperature: {Operating: -40°C to +85°C} & {Storage: -50°C to +100°C}
 Humidity: MIL-STD-202F, Method 103B, Cond. B (96 hours at 95% R.H.)
 Shock: MIL-STD-202F, Method 213B, Cond. B (75G, 6mSec)
 Vibration: MIL-STD-202F, Method 204D, Cond. B (.06" double amplitude, or 15G)
 Altitude: MIL-STD-202F, Method 105C, Cond. B (50,000 Feet)
 Temp. Shock: MIL-STD-202F, Method 107D, Cond. A (5 cycles)

Outline
 ("A" = 2.180" [55.4mm])

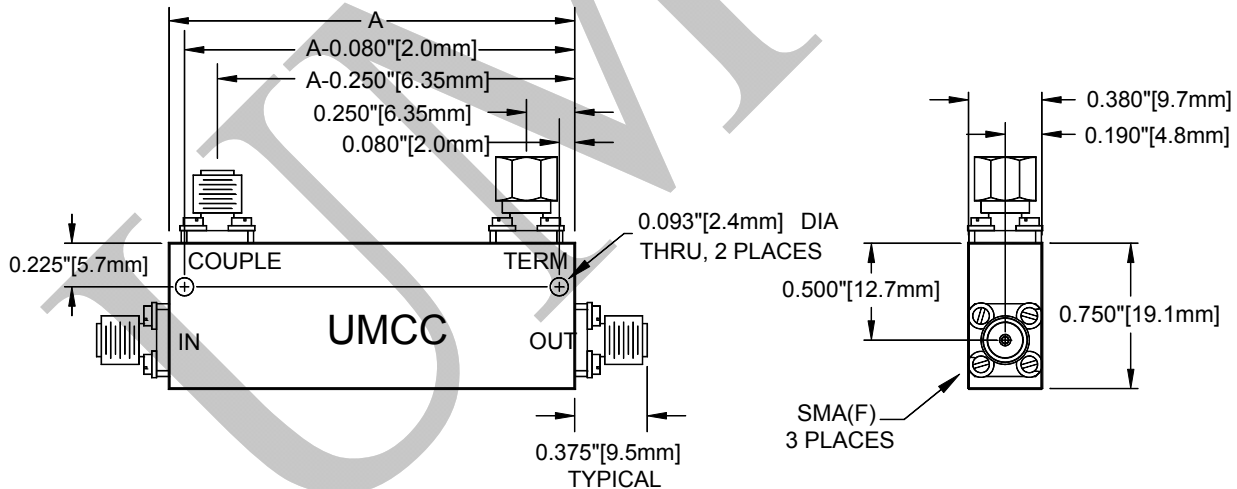

Weight	Tolerances
1.5 oz [42.5 g]	±0.015" [±0.38mm]